



DDC at a glance
Dec 19, 2022

Agenda

1. DDC at a glance	3
2. Process & Control Point	15
3. Breakdown Cost	20
4. Line Process & Product visit	23
5. Q&A	

Company Overview

DDC SPROCKET CO.,LTD.

Was found in 1992. We started from producing motorcycle parts including sprockets.

Since we established the business. We always concern about quality efficiency and customer's responsiveness. We realize that to meet our customers' need is to produce quality with reasonable prices.

The factory is equipped with perfect equipment and Advanced technology. All the machine in the factory height precision from Japan, Europe.

Because we consider of cost efficiency to be a very Important issue that will make us meet our clients' need, For each step of the products' process, we are very careful when we make the products.



Mission/ Vision/ Goal _ Our aspiration



Missions

“Committed to developing excellence in metal innovation manufacturing. Meet the needs for maximum satisfaction of customers. Responsible for society and the environment and stakeholders such as customers, suppliers, shareholder.”

Vision

“World-Class innovative designer and manufacturer of metal product with precision Fine Blanking Technology.”

Goal

“Building customer confidence in quality and delivery. Add value to products and services. Create a business system efficient work. Bringing technology to help increase efficiency.”



Our company and customer location

Location

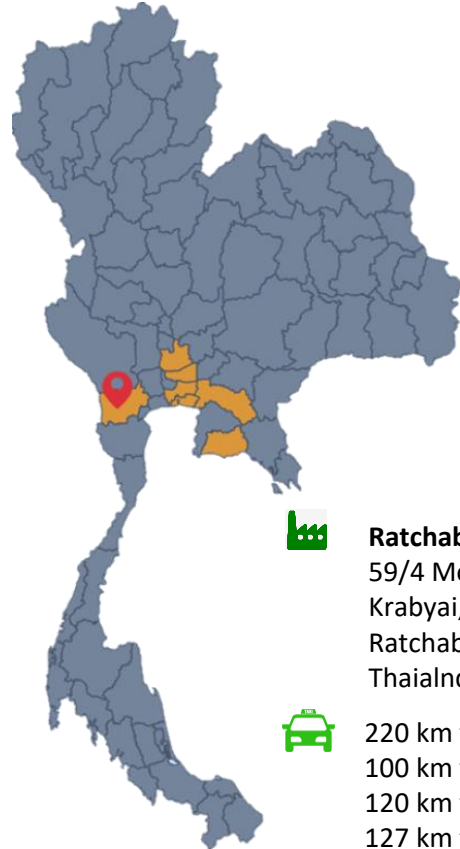

Ratchaburi :

59/4 Moo2, Tumbon Krabyai, Amphur Banpong, Ratchaburi, 70190 ThaiInd.



220 km to Lamchaban seaport
100 km to Bangkok seaport
120 km to International Air port
127 km to HLAS (Honda Logistics Asia)
180 Km to Thai Honda Co., Ltd. (PE Factory)

Our customer



Oversea customer

- Cambodia
- Indonesia
- Sri lanka
- Loas
- Myanmar
- Philippine
- Vietnam
- UAE
- UK
- Italy

Domestic customer

- Automotive



- After market



- Agriculture



- Others

Company Overview

Key aspects.

- ▶ Land plot size : 48,000 sq.m.
- ▶ Production space : 7,300 sq.m.
- ▶ 2nd hall production available : 4,500 sq.m.
- ▶ Available space : 36,200 sq.m.
- ▶ Headcounts in 2022 (Direct & Indirect) : 222 HCos base on Nov,2022

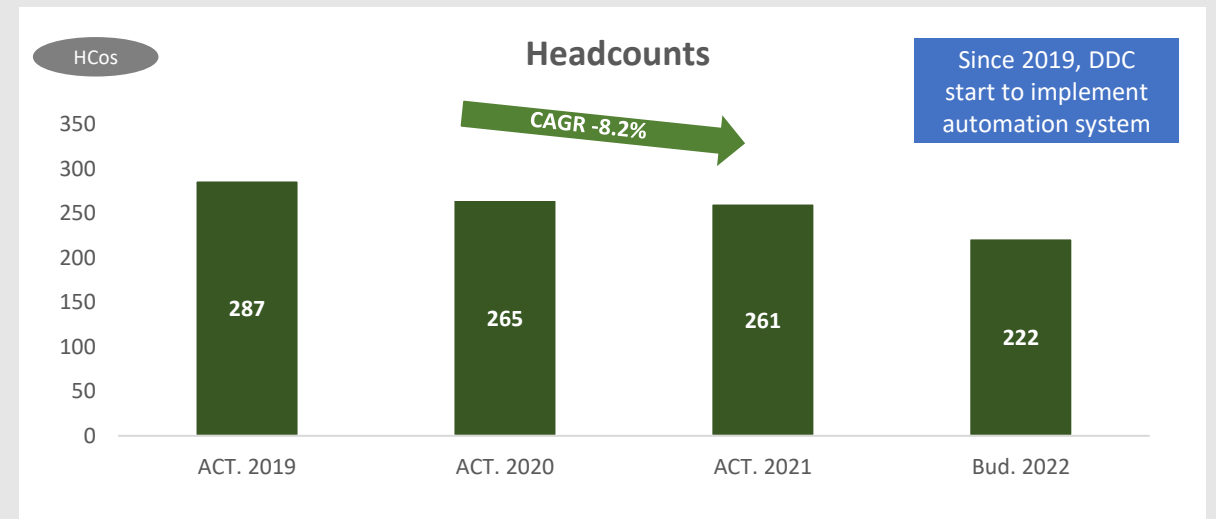
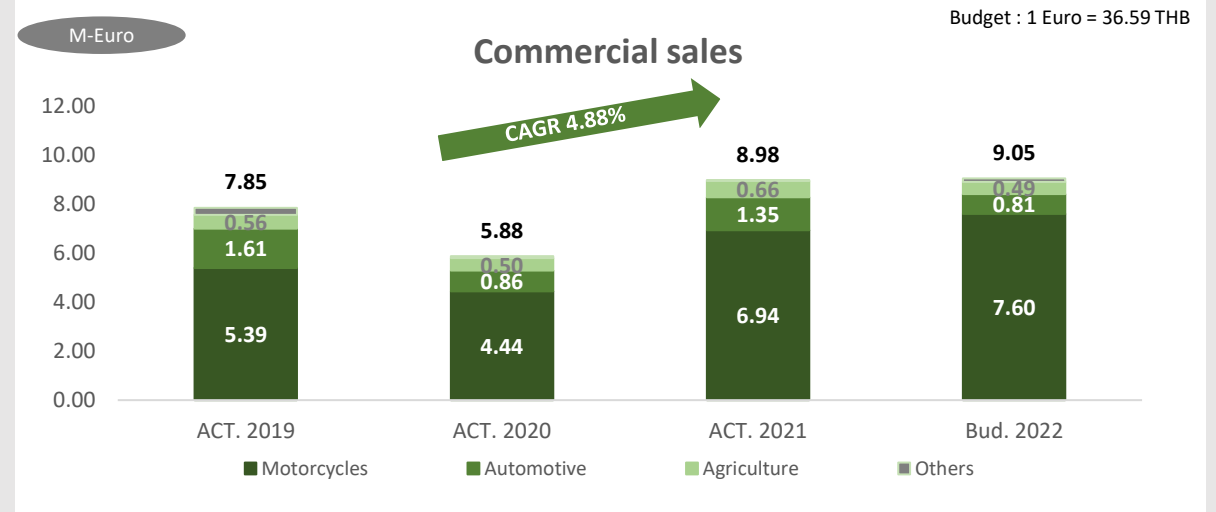

Development milestone

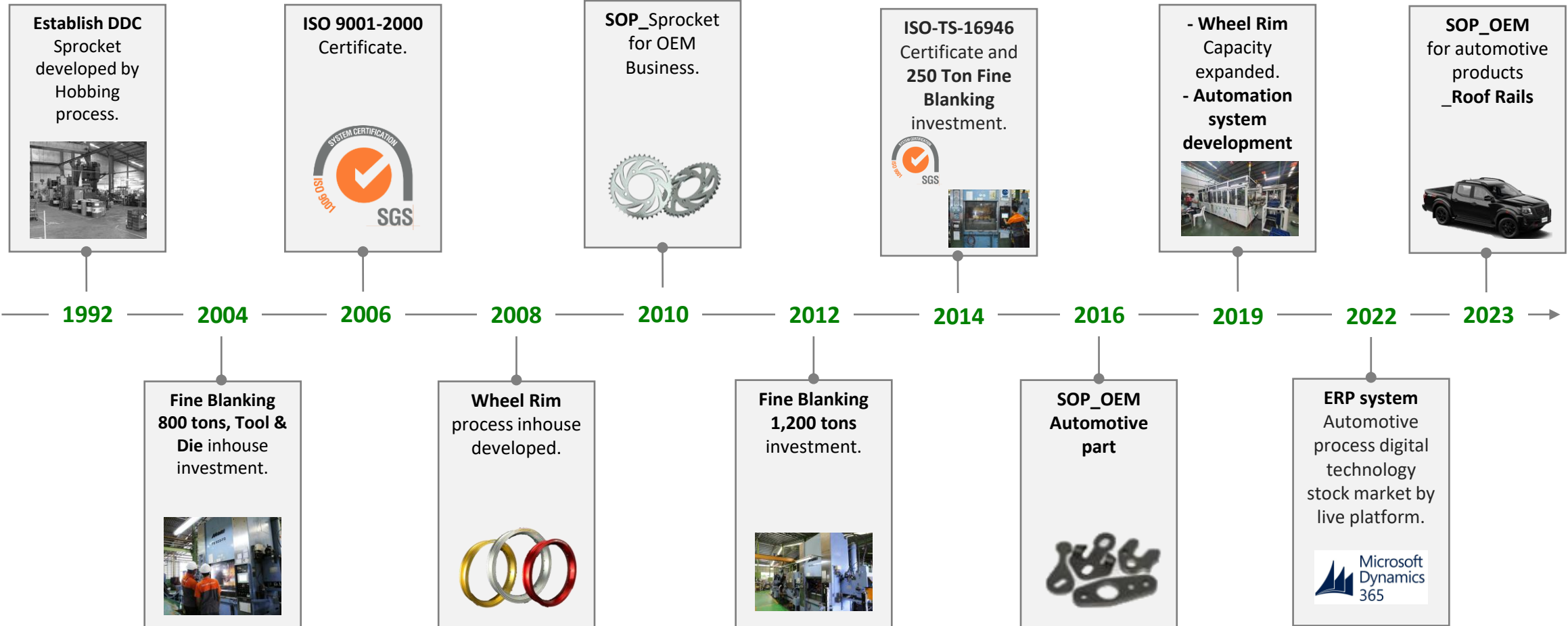

Core technology _ Fine Blanking technology

Conventional blanking process

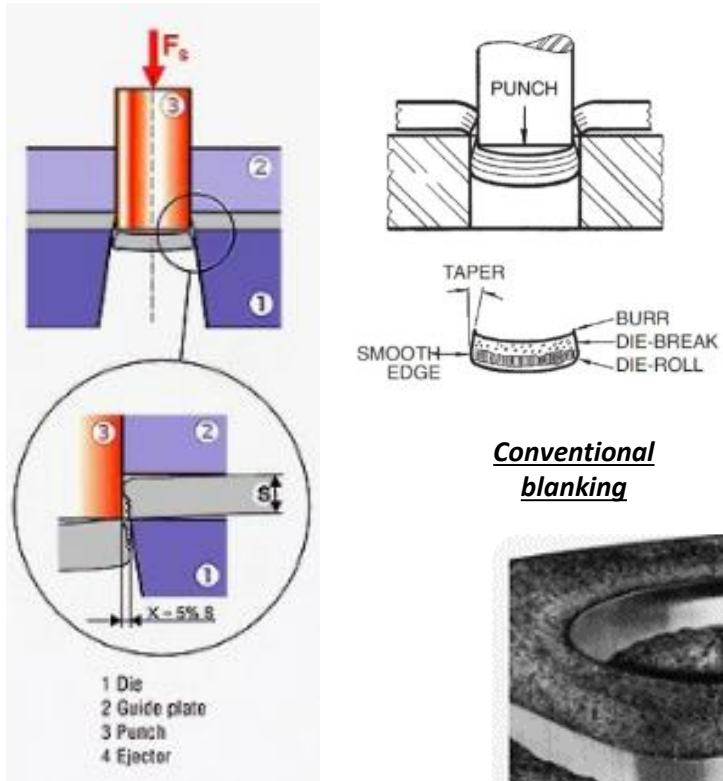

Conventional blanking

Fine blanking process



Fine blanking



The FB press uses three independently adjustable pressures (Triple Action Mode) for blanking operation.

Fine blanking is a sheet metal forming process which shears the metal strip to achieve smooth edge without tear. A typical Fine blanking tool is a single-station compound tool for producing a finished part in one press stroke.

The only addition operation needed is the removal of a slight burr. The process requires a triple-action fine-blanking press. V-ring pressure, counter-pressure, and blanking pressure forces are individually and infinitely adjustable.

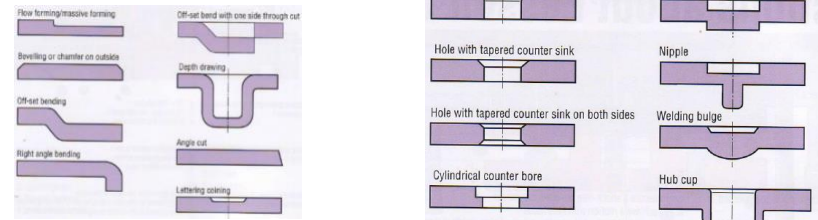

Our products

Automotive Products

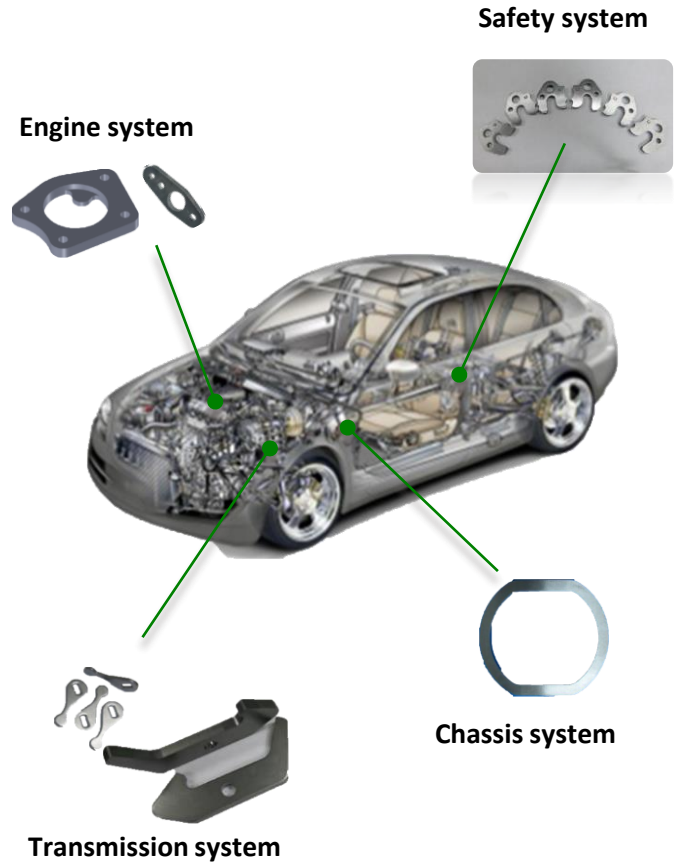

Motorcycles Products



Agriculture Products



Quality control equipment

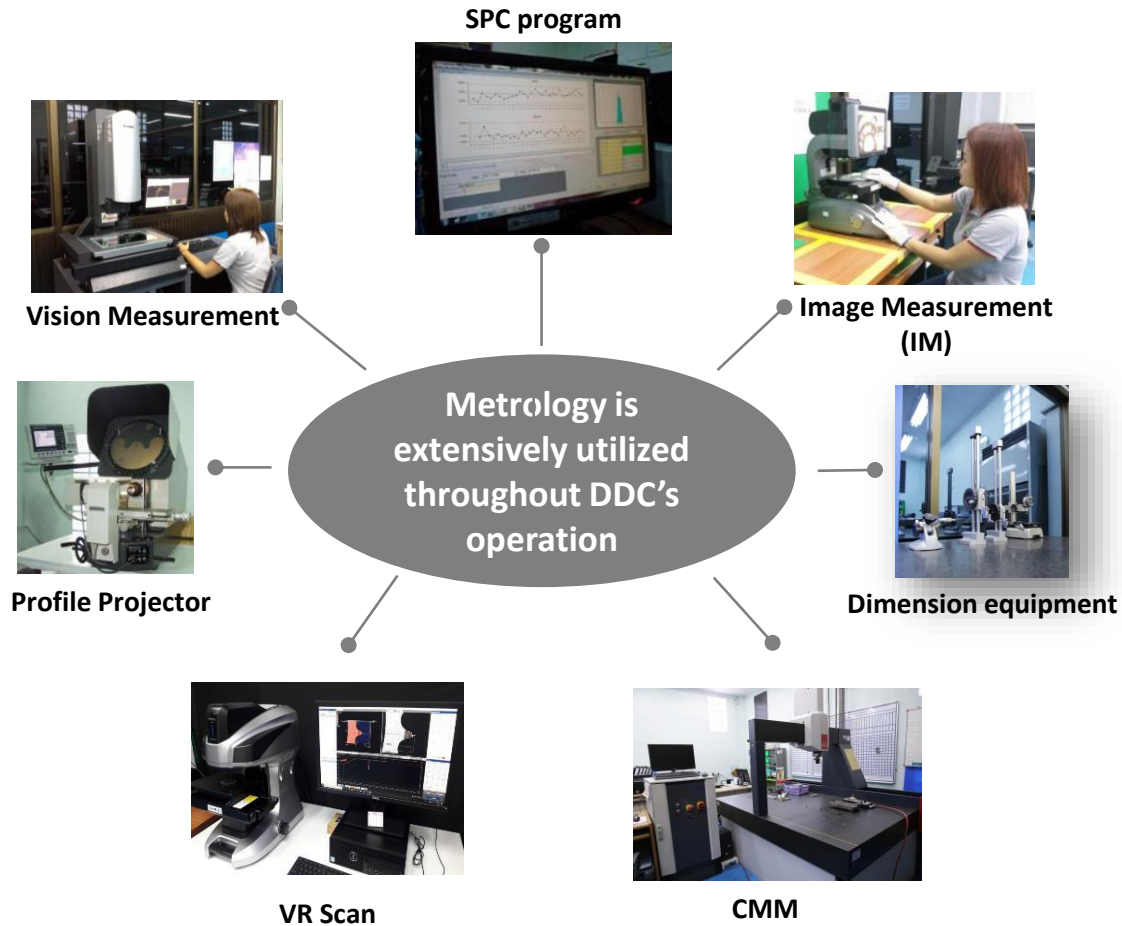

Dyno motorcycles tester machine



Propose

- life ability function sprocket test
- Simulate load or load conditions of the motorcycle as if running on real roads
- can be selected from 1% to 100% of the load

Capacity

- Measures up to 300 HP
- Max. Axle torque up to 550 Nm
- Max. engine torque 530 Nm
- Ma. Roller torque 550 Nm
- Speed Max 300 km./hr

Green energy and CSR

Green factory by green energy



Key aspects

Since June, 2022 : DDC company start up for green energy by photovoltaic

- 1st stage for ware house area [June, 2022]
- 2nd stage for indirect office [Q-2 of 2023]
- 3rd stage for production office. [Q-4 of 2023]
- For production line, under feasibility study for ROI.

CSR activity

DDC sprocket family's donation



Blood donation activity



CSR-DIW โครงการความรับผิดชอบต่อสังคมของผู้ประกอบการ



พัฒนาชุมชนร่วมกับผู้นำชุมชนบ้านอ้อฮีเขียว อ.บ้านโป่ง

Award

Award



Award from customer

- Honda Manufacturing Thailand
- Kawasaki motor Thailand
- Suzuki Motor Thailand

House of achievement



BAI PO Business Award by SASIN [Siam commercial bank & Chulalongkorn university]

On 20 February 2019 DDC get selected for BAP PO business award to praise and admire small and medium business entrepreneurs or SMEs with sales from 50 million baht – 500 million baht and have been in business for at least 3 years with the ability to adapt. grow your business and success and to be a role model for other Thai entrepreneurs has been used as a guideline for conducting business



Award received in field

- Innovation Enterprise
- Operational Vest Practice
- Entrepreneurship

Agricultural gardening

Garden nearly house is the idea from Mr. Komdej Vichitjarusgul Chief Executive Officer of DDC Sprocket Co., Ltd. We do an agricultural gardening for ourself. We do the cultivation of organic vegetables and fruits. The objective is for everyone to have non-toxic vegetables and fruits to eat and to be healthy. And our staff can reduce some expense. We start doing garden since April 2022 until now, vegetables and fruits can be harvest.





DDC SPROCKET CO.,LTD

Less is more



DIAMOND DIMENSION CO.,LTD

บริษัท ไดมอนด์ ไดเมนชัน จำกัด

59/3 M.2 Krabyai, Banpong, Ratchaburi, THAILAND 70190
Tel: 66-32-268-324-26 Fax: 66-32-268-327



Lotus

DIAMOND DIMENSION
Associated company

Our products



Sculpture electric pillar

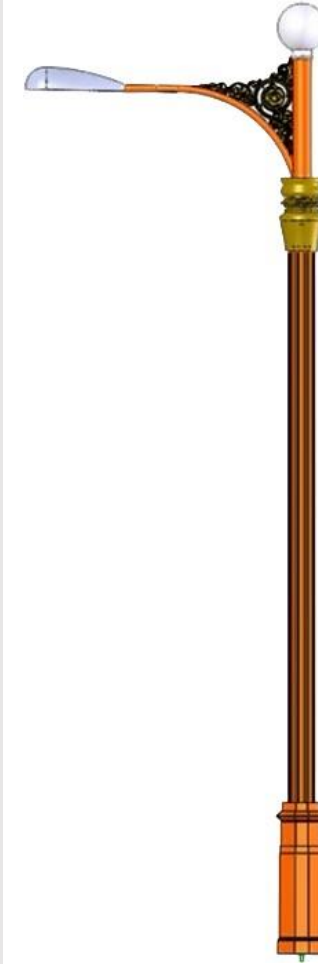
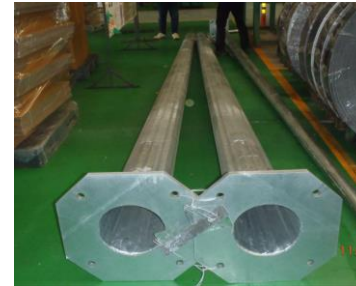
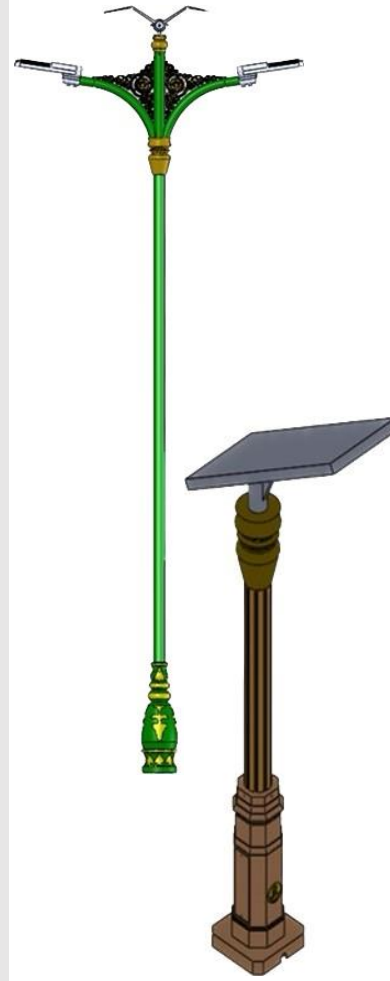

Our products



Roll Bar / Aluminum profile finishing

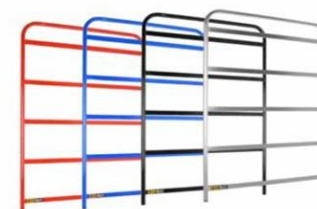

Our process line



Welding robot machine



Production Cap

Line make up June, 2022

- Robot Machine 2 machine
- Capacity 380 Set per day

Welding product

Bracket Arial part



Structure Work



Our process line



Zinc Plating Line



Capacity

- Hanger Line
- 78,000 Pcs/months.



Zinc plating product

Next Step



EDP Line



Target Capacity

- Sprocket Line
- 100,000 Pcs/months.



Anodize Line



Capacity

- Aluminum Wheel Rim Product
- 50,000 Pcs/months.

